

LKZ: 80461

Modellname / Model name / Nom du modèle / Modellnamn / Nome modello / Název modelu / Modelnaam / Ime modela / Numéro Modelo / Modell neve / Название мо дели / Názov modelu / Ime modela / Denumire model / Наименование на мо дела / Nazwa modelu

Amanda

Modellnummer / Number / Numéro du modèle / Numero / Номер на мо дела / modello / Číslo modelu / Modell száma / Éislo modelu / Številka modela / Număr model / Broj modela / Modelnummer / Numer modelu

1393-405-01
1393-405-07

Type / Tipo / Típus / Тип / Тип / Tip

405

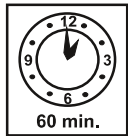
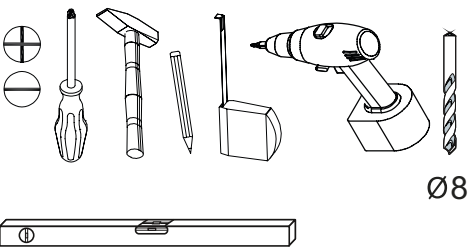
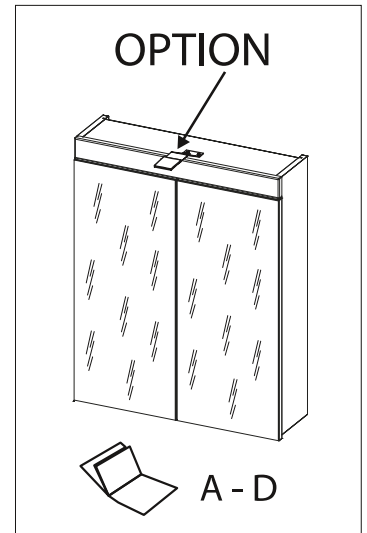
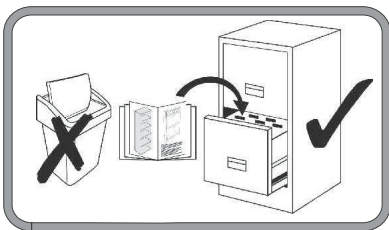
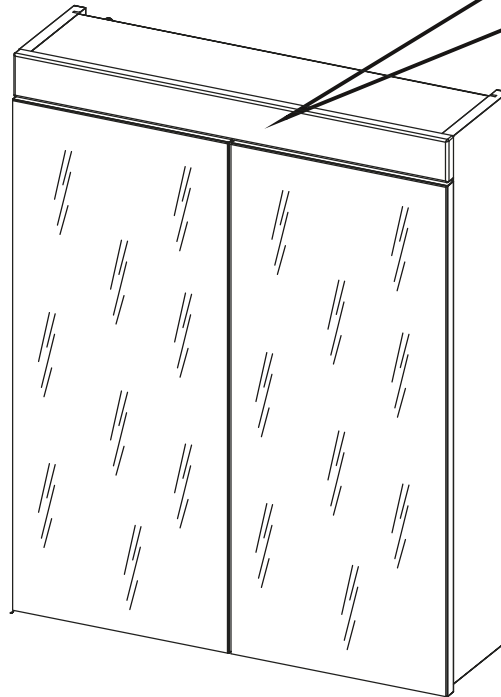
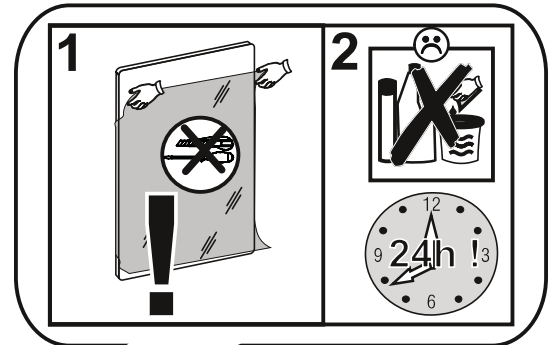
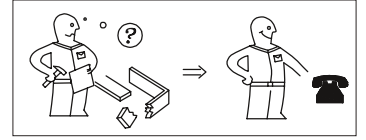
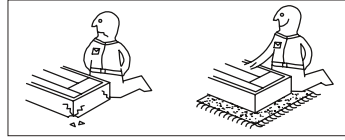
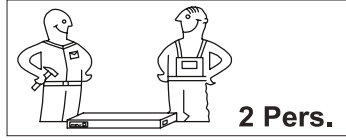

festziehen / tighten / За тегнере / serrer / stringere / utåhnot / vasttrekken / zategnuti / strângere / zwiázac / zacisnac / szorosan meghúzni / pevne dotiahnut' / trdno pritegniti / затянуть / dra át



eindrücken / press in / enfoncer / wcisn / ać / ribattere / zatla čit / Вкарайте / indrukken / benyomni / stăcit' / vtisniti / tryck in / introducere prin apăşare / вдавить



ausmessen / measure / mesurer / misurare / opmeten / izmeriti / miara / kimérni / izmeriti / măsurare / измерить / změřit / Измерете / mät upp / zmierzyc



drücken / press / presser / stisknout / На тисне те / vtisniti / nasinac / drukken / pritisnuti / nacisnac / pritisniti / нажаť / (meg)nyomni / apăşare / tryck fast / nacisn



einschlagen / hammer in / beverni / slå in / frapper au marteau / infossare / Zabit' / zarazit / Набийте / zabiti / wbić / introducere prin bătaie / забить / zatloutt



Drehen - wenden / przekrećić - odwrócić / Keren - omdraaien / Girare - Ruotare / Okrenuti - ubrnuti / Retourner - renverser / Turn over - turn around / Otočte - obratite / Завъртете - обвърнете / Obrnite list / Intoarceți - rotiți / Vrid runt - vänd / прокрутить - повернуть / otočit - obrátit / elforgatni - megfordítani

LKZ: 80461

Modellname / Model name / Nom du modèle / Modellnamn
Nome modello / Název modelu / Modelnaam / Ime modela
Numéro Modello / Modell neve / Название модели /
Názov modelu / Ime modela / Denumirea model /
Наименование модели / Nazwa modelu

Amanda

Modellnummer / Number / Numéro du modèle
Numero / Номер на модели / modello
Číslo modelu / Modell száma / Íslo modelu
Številka modela / Număr model / Broj modela
Modelnummer / Numer modelu

1393-405-01
1393-405-07

Type / Tipo / Típus / Typ / Тип / Tip

405

D Unser Direktservice für Beschädigte
Sollte Ihnen ein Beschädigter fehlen, können Sie diese Servicekarte
direkt an die untenstehende Adresse mailen. Wir können allerdings
nur Beschädigte auf diesem Wege verschicken. Sollten Sie eine
andere Beanstandung an Ihrem Möbelstück haben, so wenden Sie
sich bitte direkt an Ihr Möbelhaus.

GB Our direct order service for fitting
If a fitting part is missing, you can e-mail this service card directly
to the address below. However, we can only send fitting parts in
this way. If you have any other cause for complaint concerning
your item of furniture, please contact your furniture store directly.

CZ Naše přímé služby pro kování
Chybí vám nějaký díl z kování, můžete tuto servisní kartu odeslat
e-mailem přímo na níže uvedenou adresu. Touto cestou však
můžeme zoslat jen díly kování. Pokud byste reklamovali jiný díl
nabytku, obraťte se přímo na svého prodejce nabytku.

F Bien etudier la notice de montage
S'il vous manque une ferrure, veuillez envoyer directement la présente
carte service à l'adresse e-mail indiquée ci-dessous. Cependant, ceci
nous permet uniquement d'envoyer des ferrures. Pour tout autre type
de réclamation concernant votre meuble, veuillez contacter
directement votre magasin d'ameublement.

I Il nostro servizio diretto per l'ordine della ferramenta
Qualora vi dovesse mancare un pezzo di fissaggio, allora vi
preghiamo di inviare questa carta di servizio immediatamente
all'indirizzo sottostante. Possiamo inviare i pezzi di fissaggio
solamente per mezzo di questo procedimento. Qualora dovete
avere qualche altra reclamazione in merito al mobile, allora vi
preghiamo di rivolgervi direttamente al Vostro Negozio di mobili.

BG Нашта директна услуга за обкова
Ако липсва ат части от комплекта, попълнете те наст оящата
сервисна карта и ни я изпратете на е-mail адреса, посочен
по-долу. По този начин можем да доставим само липсващи
елементи от обкова. Ако установите друг дефект по мебелта,
ви съветваме да се обърнете към мебелната къща/магазин,
от който сте закупили стоката.

NL Onze directservice voor losse onderdelen
Wanneer er een onderdeel ontbreekt, kunt u deze servicekaart
direct aan onderstaand e-mailadres sturen. Wij kunnen langs deze
weg echter alleen beslagdelen versturen. Mocht u een ander
probleem aan uw meubel hebben, verzoeken wij u contact op te
nemen met uw meubeldealer.

PL Nasz bezpośredni serwis części montażowych
Jeżeli brakuje części koniecznych do montażu, prosimy o przesłanie
nam niniejszej karty serwisowej na niżej podany adres e-mailowy.
W ten sposób możemy przesłać Państwu tylko brakujące części.
W przypadku innych reklamacji dotyczących mebla, prosimy zgłosić
się do salonu meblowego, w którym został dokonany zakup.

HR Servis za okove
U slučaju da nedostaje neki od dijelova molimo vas da na dolje
navedenu mail adresu pošaljete ovaj servisni obrazac. Na ovaj način
možu se dostaviti samo okovi. U slučaju da imate dodatne prigovore
vezane uz komad namještaja molimo vas da se obratite izravno
trgovini namještaja gdje je isti kupljen.

HU Direktszolgáltatunk vasalatoik esetén
Ha hiányzik egy vasalat, ezt a kártyát közvetlenül elküldheti az
alább található címre. Azonban csak vasalatoikat tudunk így
küldeni. Amennyiben másfajta reklamációt áll fenn bútorárbaját
illetően, forduljon közvetlenül a bútorháznál.

SK Naš priamy servis pre časti kovania
Ak by Vám chýbala nejaká časť kovania, môžete poslať
túto servisnú kartu poslať e-mailom na nižšie uvedenú
adresu. Dieľta kovania vieme poslať iba týmto spôsobom.
Ak by ste mali inú reklamáciu ohľadom Vášho nabytku,
obráťte sa priamo na Vašu predajňu nabytku.

SLO Naše direktno uslužne storitve za okovje
Če vam manjka kakšno okovje, lahko to servisno kartico pošljete
po e-pošti direktno na spodnji naslov. Po tej poti vam lahko
pošljemo samo okovje. Če želite reklamirati kakšen drug del
pohištva, se obrnite neposredno na vašo trgovino pohištva.

RO Service-ul nostru direct pentru feronerie
În cazul în care vă lipsește o piesă de feronerie puteți să trimiteți
direct acest card de service prin e-mail la adresa de mai jos. Noi
nu putem expedia piese de feronerie decât pe această cale.
Dacă aveți o altă reclamație referitoare la piesa de mobilier
atunci vă rugăm să vă adresați direct la magazinul dvs. de mobilă.

RUS Наш прямой сервис для поставки фурнитуры
Если окажется, что у Вас не хватает того или иного элемента
фурнитуры, Вы можете отправить сервисную карту по факсу
непосредственно на нижеприведенный электронный
адрес. Однако, таким образом мы сможем переслать лишь
фурнитуру. Если же у Вас возникнут иные претензии
относительно приобретенной мебели, пожалуйста, обращайтесь
непосредственно в организацию, осуществляющую продажу.

S Vår direktservice för beslagdelar
Om du saknar en beslagdel kan du skicka detta servicekort direkt
till e-postadressen som anges nedan. Tänk på att detta är den enda
möjligheten att skicka beslagdelar till dig. Om du vill reklamera din
möbel av annan anledning måste du kontakta ditt möbelhus direkt.

ES Nuestro servicio directo para accesorios
Si le falta algún accesorio, puede enviar esta tarjeta de servicio directamente
a la siguiente dirección. No obstante, por este método solo podemos
enviar accesorios. Si tiene alguna otra objeción sobre su mueble, consulte
directamente con su mueblería.

TR Donatılar için doğrudan servisimiz
Bir donatınız eksikse bu servis kartını doğrudan aşağıda bulunan adrese
doğrudan mail yazabilirsiniz. Sadece bu yolla donatılar gönderiliriz.
Mobilyanızda başka şikayetleriniz varsa lütfen doğrudan mobilya satıcınıza
danışın.

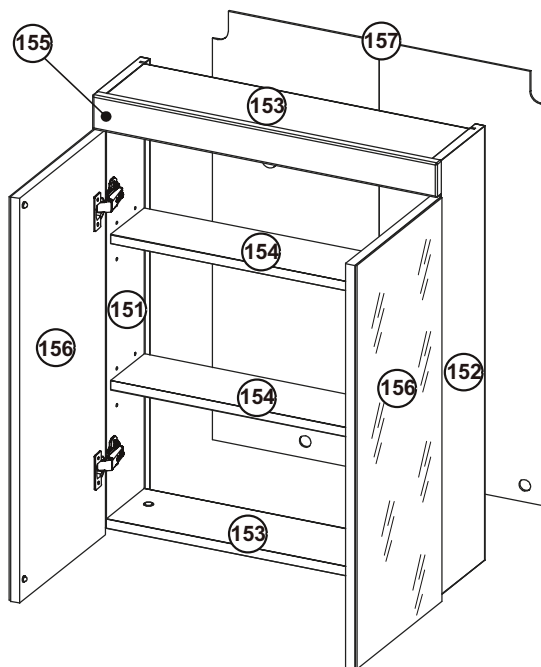

max.

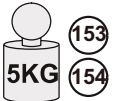

Nr	Masse mm	Colli	Anzahl
151	760 152 16	1/1	1
152	760 152 16	1/1	1
153	568 132 16	1/1	2
154	567 117 16	1/1	2
155	601 60 16	1/1	1
156	708 298 16	1/1	2
157	755 290 2,5	1/1	2

B151

8x35 A20 x8	G21B x4	G21A x4	4x13 D40 x8	H20 x8	E22 x2
C21 x4	C22 x4	3x14 D37 x17	C20 x4	U25 x1	M23 x1
M20 x2	3x16 D20 x4	F20 x4	U20 x4	5x50 E21 x6	F21 x2

Grund der Beanstandung / Reason of the objection:

Möbelhaus / Furniture store:

Name / Name: _____ Telefon / Telephone: _____

PLZ / postal code: _____ Ort / City: _____

Strasse / Street: _____

Haus-Nr. / House No.: _____ @E-Mail: _____

Değerli müşterimiz, evde kullanım için tasarlanan iç mekan programımızdan bir mobilya satın aldığınız için teşekkür ederiz. Lütfen teslimat kapsamının eksiksiz olup olmadığını kontrol edin ve montajdan önce aşağıdaki önemli bilgileri dikkatlice okuyun ve daha sonra üçüncü şahıslar tarafından da kullanılmak üzere saklayın.

Mobilyalarımız amaçlandığı şekilde kullanılmalıdır. Amacı dışında kullanım, maddi hasarları veya bazı durumlarda kişisel yaralanmalara neden olabilir. Mobilyalar çocuk oyuncakları değildir. Üretici veya satıcı, amacı dışında veya yanlış kullanımdan kaynaklanan hasarlar için hiçbir sorumluluk kabul etmez.

D İ K K A T: Çocuklar veya zihinsel engelli kişiler, yaralanma ve/veya bozulma riski bulunduğundan, mobilya parçalarından, sivri uçlu nesnelere, küçük parçalardan ve ambalaj malzemelerinden daima uzak tutulmalıdır.

M O N T A J: Montaj sırasında lütfen işletim, kullanım, kurulum veya montaj talimatlarınıza uyun ve uyarı ve güvenlik talimatlarına özellikle dikkat edin. Talimatlara uyulmaması, kişisel yaralanmaya veya mobilya hasarına/güvenlik riskine neden olabilir.

Montaj / kurulum konusunda zorluk yaşıyorsanız, lütfen servis ekibimize iletişime geçin. Ekibimiz tavsiyeleriyle ve destekleriyle size yardımcı olacaktır. Montaj sadece uzman kişiler tarafından yapılmalıdır.

Ürün/ürün parçalarında değişiklikler, üreticiden/satıcıdan gelmeyen parçalarla/sarf malzemeleriyle değiştirilmesi veya kullanılması durumunda meydana gelebilecek hasarlar için sorumluluk kabul edilmez.

Ürünlere dübel ve vida gibi duvara sabitleme araçları eklenmişse, bunlar sadece sağlam ve tek tip malzemelerden yapılmış duvarlarda kullanılmak üzere tasarlanmıştır. Bir bağlantı sadece bağlantı elemanı ve duvar arasındaki bağlantı kadar iyidir. Lütfen mobilyayı sabitlemeden önce duvarınızın hem ayakta hem de asılı mobilya için uygunluğunu kontrol edin ve sadece uygun bağlantı elemanları kullanın. Olası bir delme işleminden önce delme alanında tesiat olmadığının emin olun. Sonuçta, montajı yapan kişi duvara sabitlemekten sorumludur.

Bu aynı zamanda elektrikli parçaların ve diğer yapısal aksesuarların montajı için de geçerlidir. Elektrikli parçaların ve diğer aksesuarların montajı için sadece yetkili uzman personel tarafından yapılabilir. Tüm elektrik ve yapısal kurulumlar, eyletmişlerinizdeki geçerli standartlara ve güvenlik yönetmeliklerine uygun olarak yapılmalıdır. Işık kaynakları için lütfen sadece izin verilen aydınlatma güçlerini kullanın. Maksimum Watt değerine uyulmaması durumunda aşırı ısınma nedeniyle yangın riski söz konusudur. Yangın tehlikesi nedeniyle aydınlatmaların üstünü kapatmak yasaktır.

Mobilyaların düzgün fonksiyonu sadece düz ve yatay konumda garanti edilir. Kapılar önceden ayarlanmıştır, ancak yerel koşullar nedeniyle yeniden hizalanması/ayarlanması gerekebilir. Lütfen maksimum yük ile ilgili ağırlık bilgilerine uyun.

Mobilyaların üzerine çıkılması yasaktır. Yanlış kullanım mobilyaların devrilmesine neden olabilir. Bunu önlemek için mobilyalar her zaman devrilmeye karşı emniyete alınmalıdır. Aşırı yük/aşırı zorlama durumunda (özellikle oyun oynayan çocuklar, insanlar, malzeme veya diğer uygunsuz etkilere nedeniyle) kırılma ve yaralanma riski söz konusudur. Kalkıcı sağlamlığı güvenceye almak için tüm vidalar ve yük taşıyan bağlantı noktaları 5-6 hafta sonra tekrar sıkılmalıdır.

B A K I M:
-Mobilya bakımıyla ilgili notlar-
Ürünümüzün keyfini olabildiğince uzun süre çıkarabilmemiz için lütfen uygun mobilya bakımıyla ilgili talimatlarımızı dikkate alın.

Temizlik sırasında temiz, kuru ve yumuşak pamuklu bir bez kullanın. Mobilyanızı kapsamlı bir temizliğe ihtiyacı varsa, bezi biraz su veya mobilya temizleyicisiyle nemlendirebilir ve ardından temizlenen eşyaları kurutabilirsiniz. Metal ve cam parçaları, üzerindeki bakım talimatlarına göre piyasada bulunan metal ve cam temizleyicilerle en iyi şekilde temizleyebilirsiniz. Temizlik maddeleri, mobilya temizliği için uygun olduklarının açık bir göstergesini taşımazlar.

Hiçbir koşulda buharlı temizleyiciler, kostik, aşındırıcı veya etkilere aşına olmadığınız diğer maddeleri kullanmamalısınız.

D İ K K A T: Çok parlak yüzeyler teslimat sırasında koruyucu bir folyoyla korunur. Bunu tamamen monte edilene ve tozu temizlenene kadar mobilya üzerinde bırakın. Koruyucu folyonun çıkarıldığı çok parlak elemanlar ancak 72 saat sonra temizlenebilir ve kullanılabilir (ortam havasında son katlaşma süresi). Yüzeylere keskin nesnelere zarar vermeyin ve asla güçlü güneş ışığına maruz bırakmayın.

T A S F İ Y E

-Tasfiyeyle ilgili notlar-
Çevre için lütfen türüne göre ayrılmış ambalaj atıklarını doğaya değil, bunlar için sağlanan atık/geri dönüşüm kutularında tasfiye edin.
Hasarlı veya kullanılamaz mobilyalar, her bir parçanın geri dönüştürülmesi için özel geri kazanım tesislerine gönderilebilir.

Artık kullanılmayan ancak hala işlevsel olan mobilyaların hemen tasfiye edilmesi gerekmez. Bunları örneğin hayır kurumlarına bağışlayın.

Yeni mobilyalarınızı güle güle kullanın.

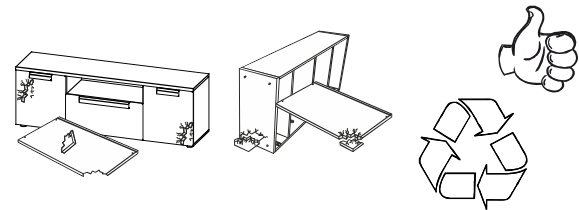
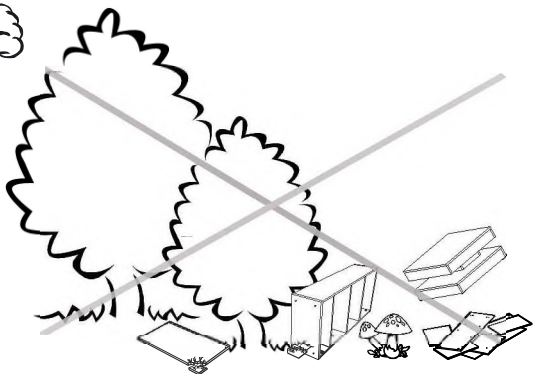
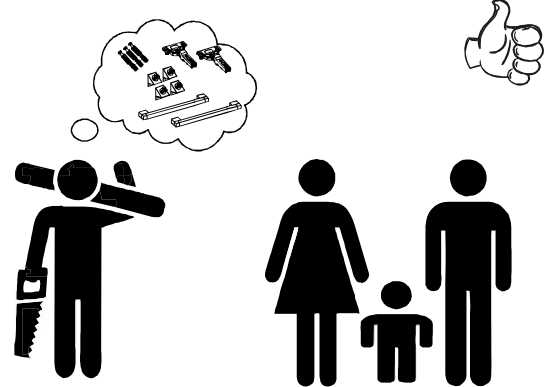
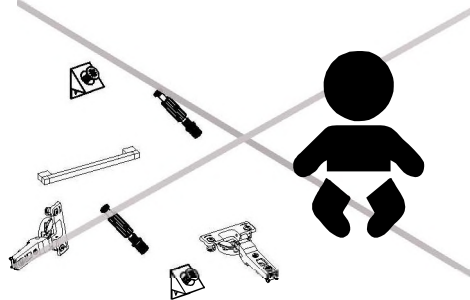
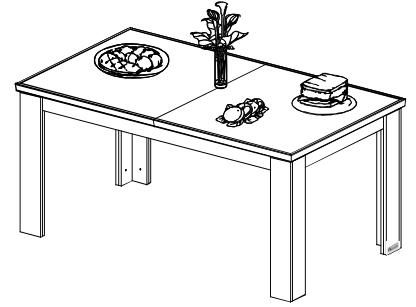
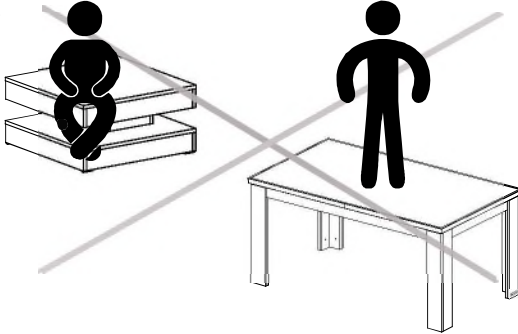
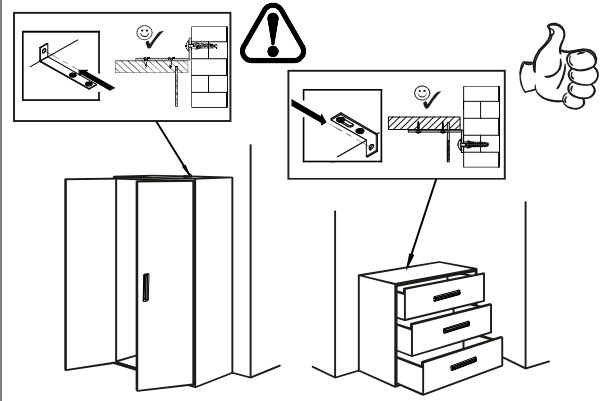
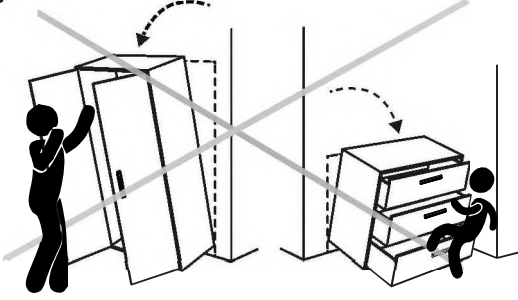

1

- A20 8x35 x8
- G21B x4
- H20 x8
- C21 x4
- C22 x4
- D37 3x14 x5
- M23 x1
- F21 x2
- U25 x1

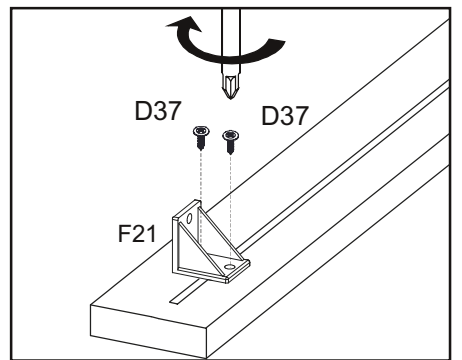
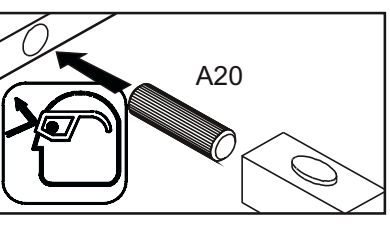
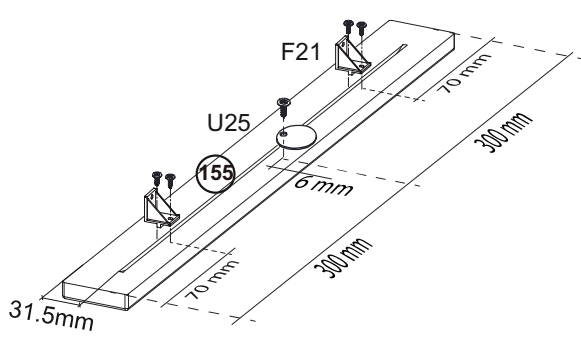
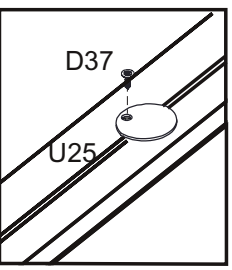
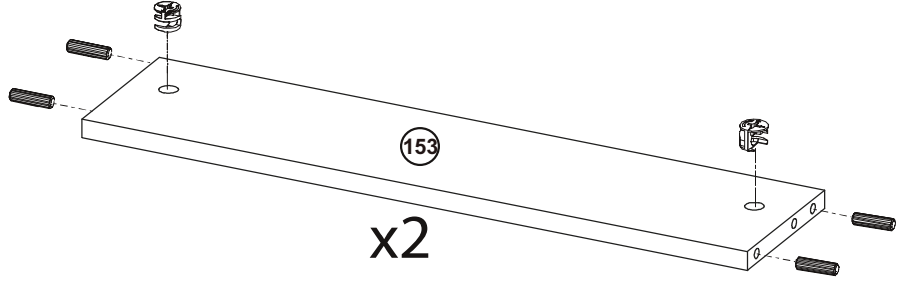
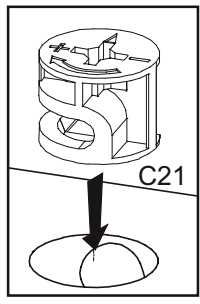
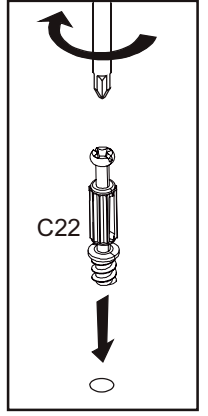
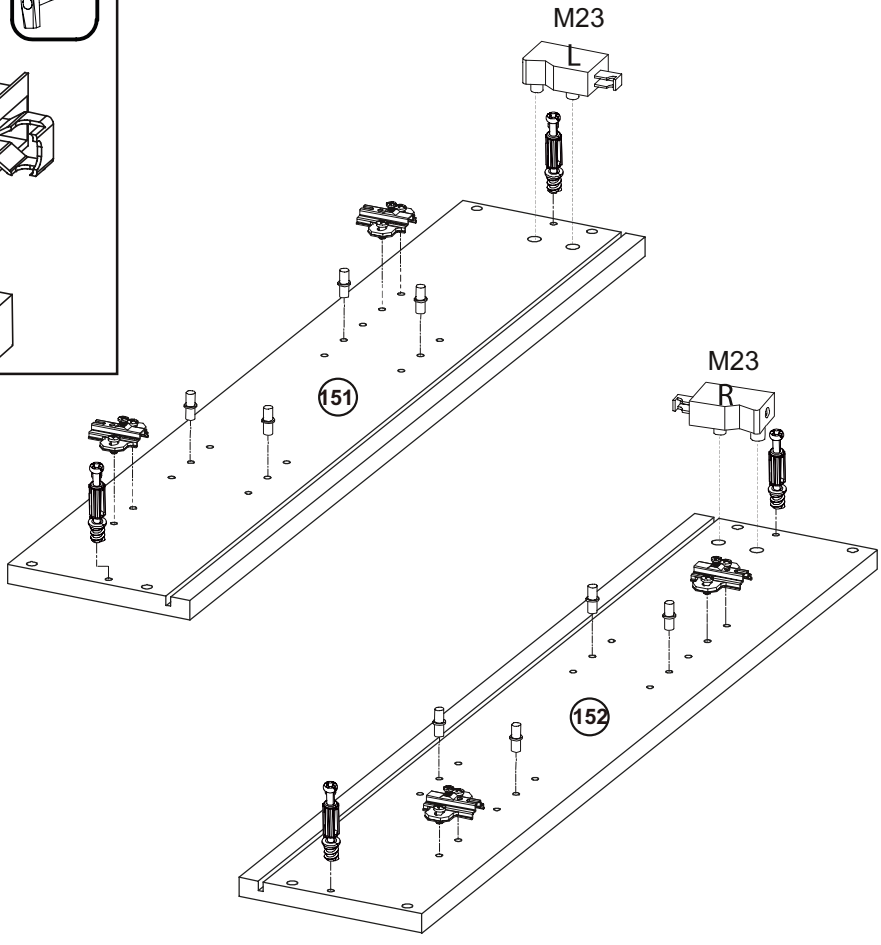
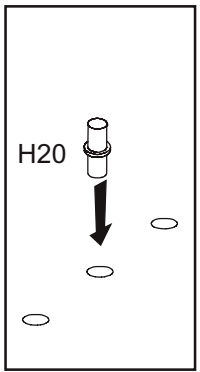
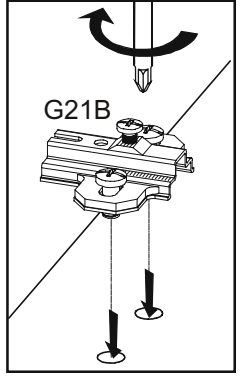
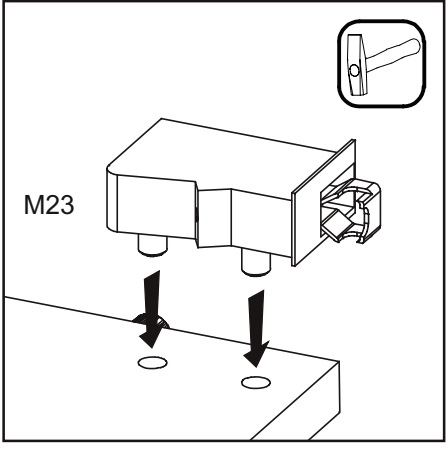

2

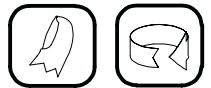
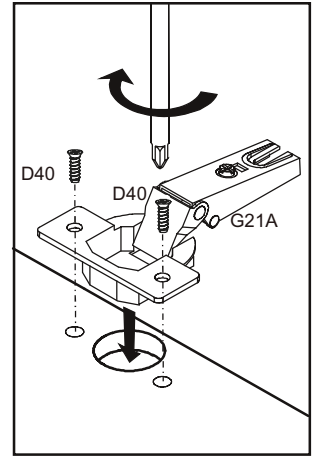
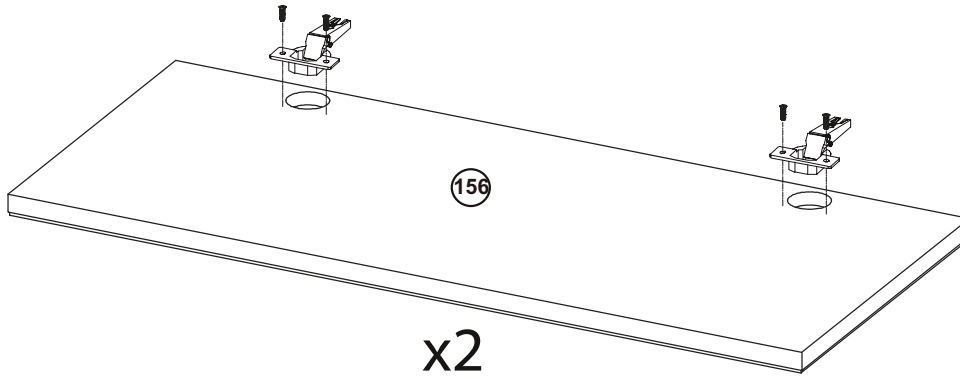
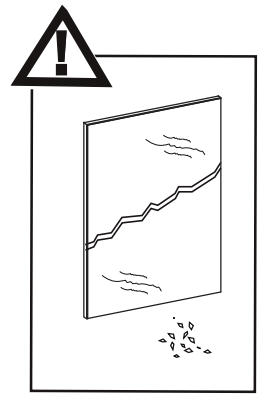
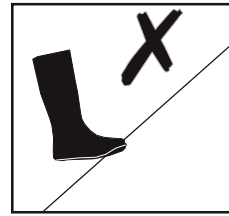
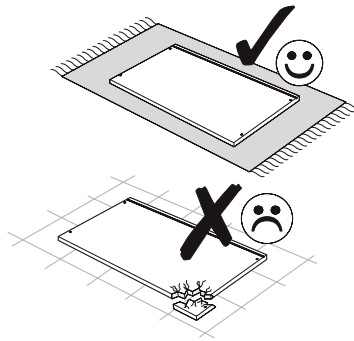
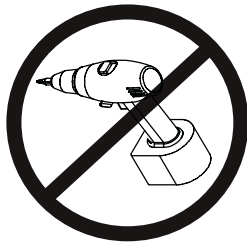
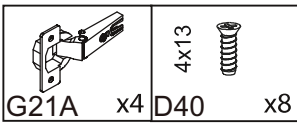

3

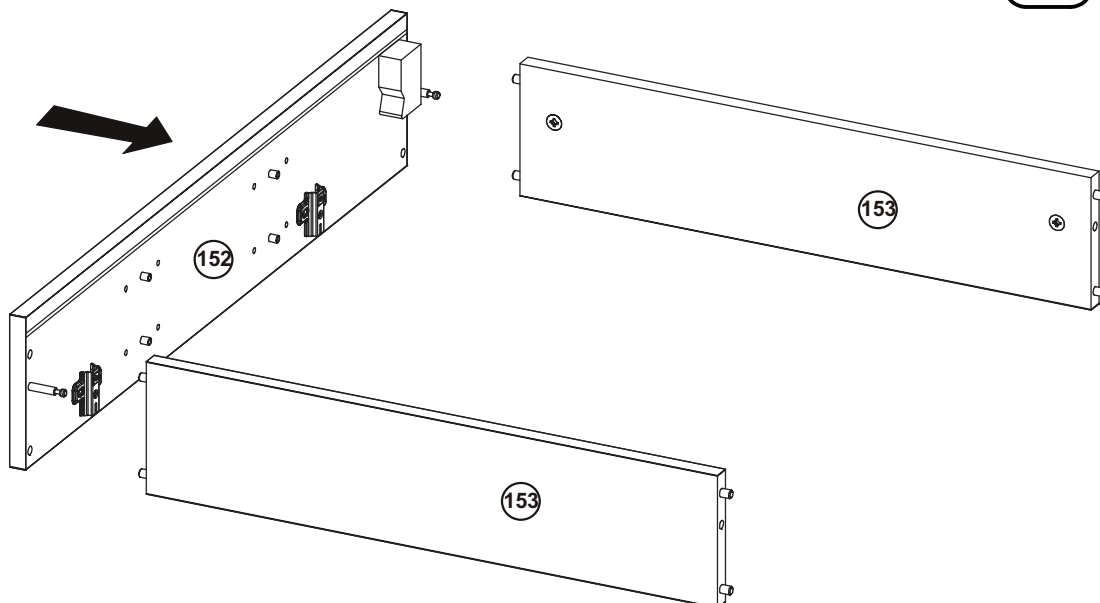
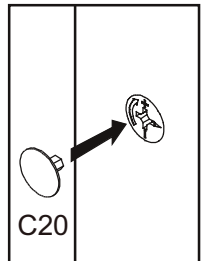
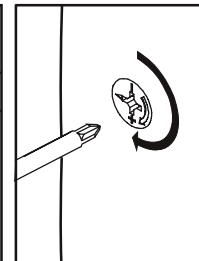
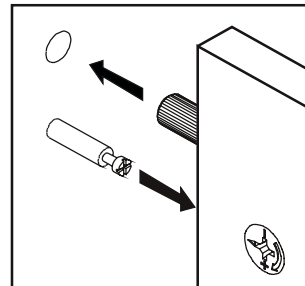
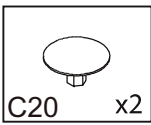

4

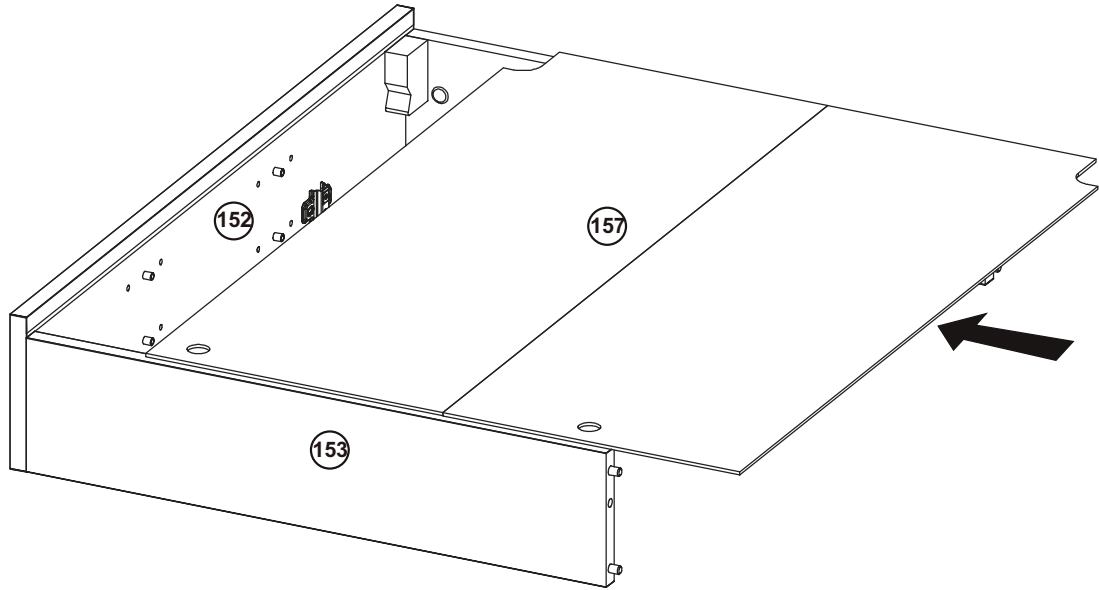

5

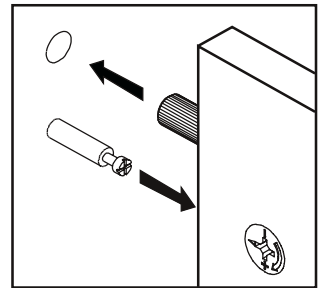
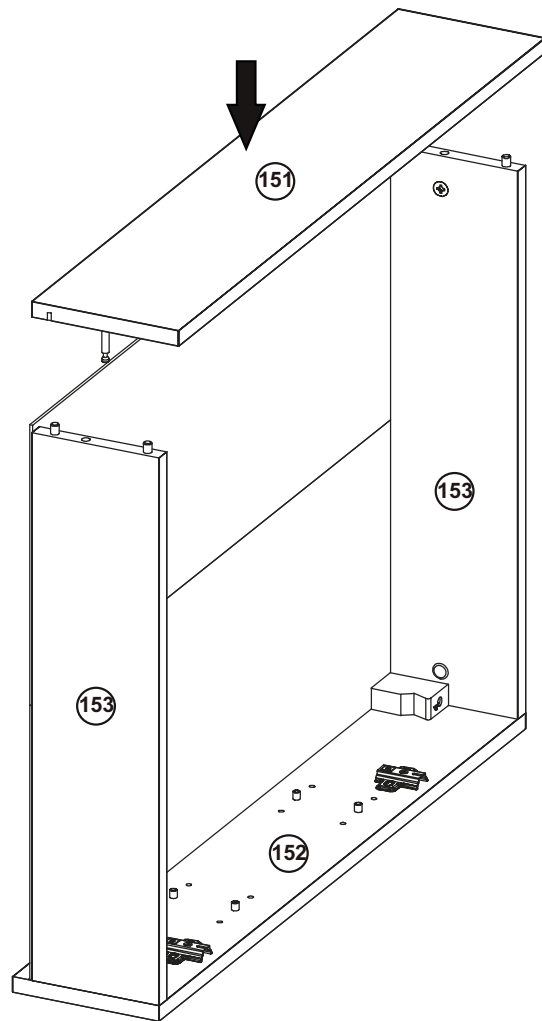

6

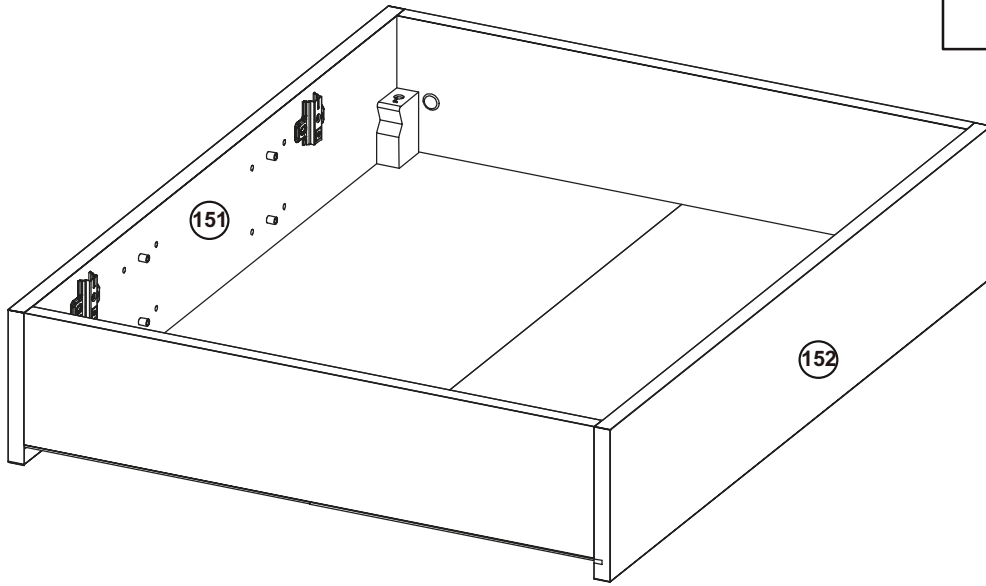
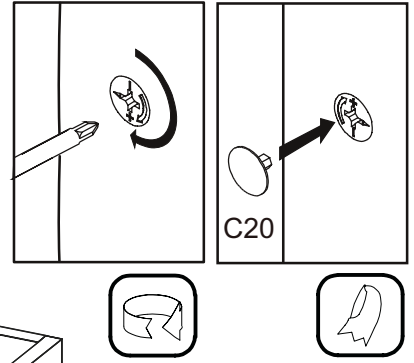
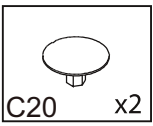

7

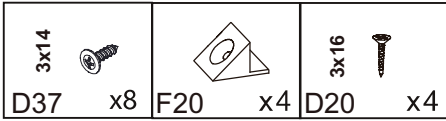

A=B

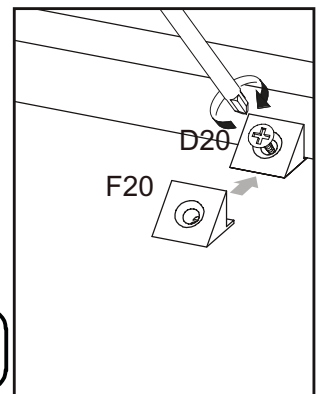
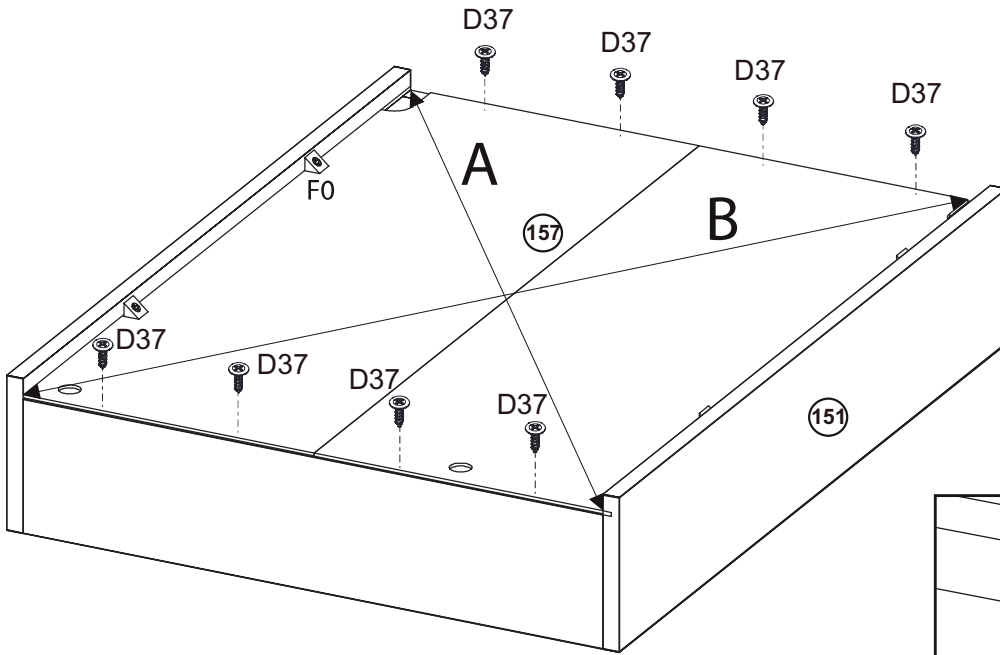

8

3x14
D37 x4

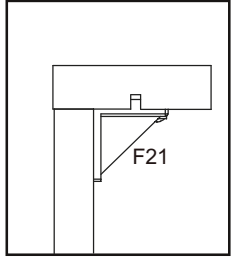
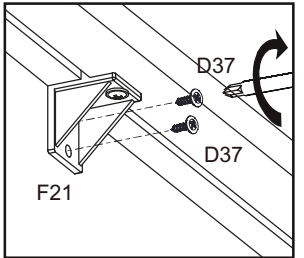
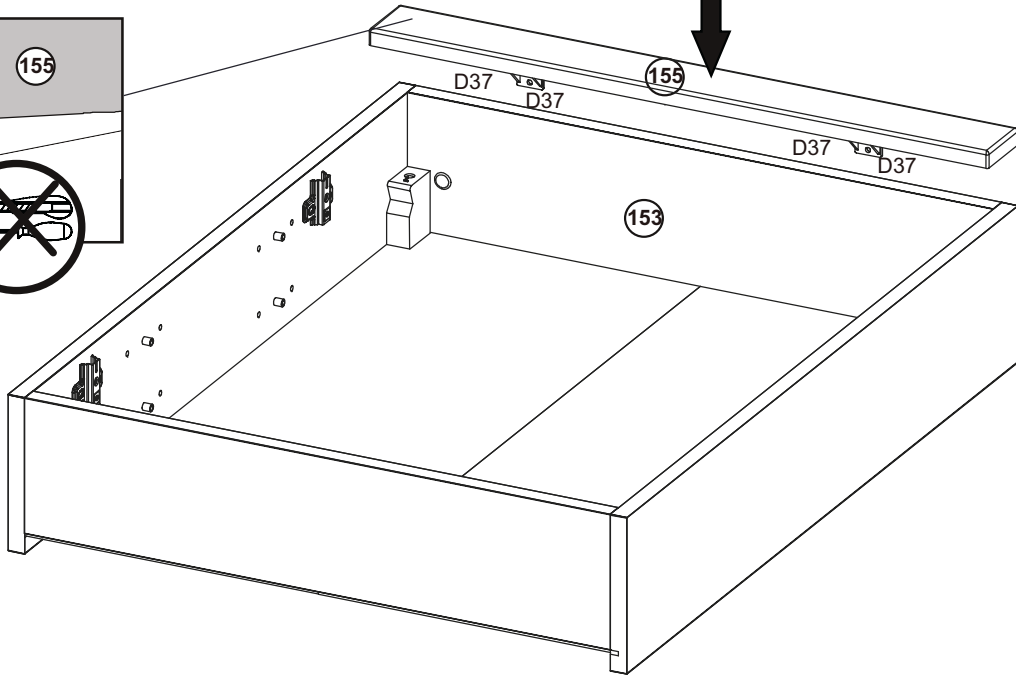
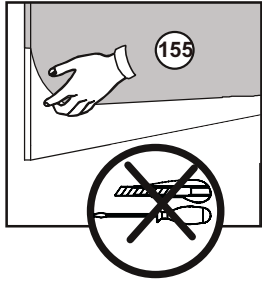

9



E21 x6

E22 x2

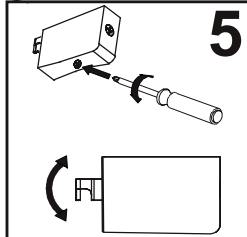
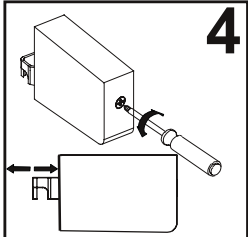
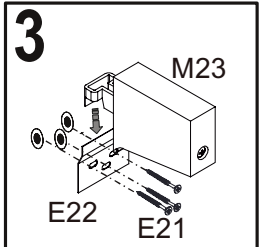
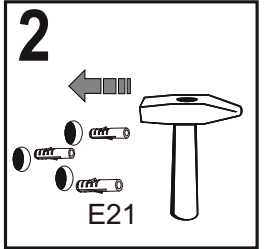
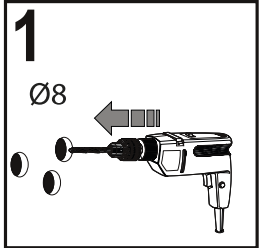
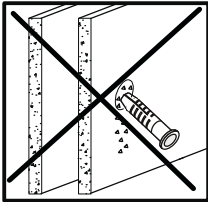
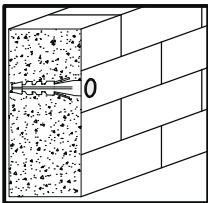
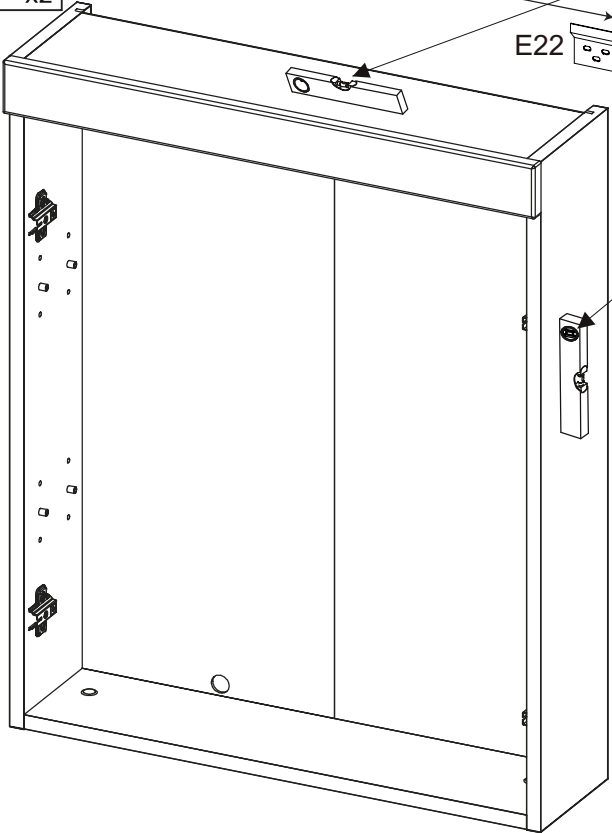
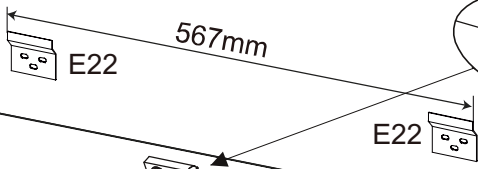
M23 x1



10

- | | |
|--|--|
|  |  |
| M20 x2 | U20 1,5mm x4 |

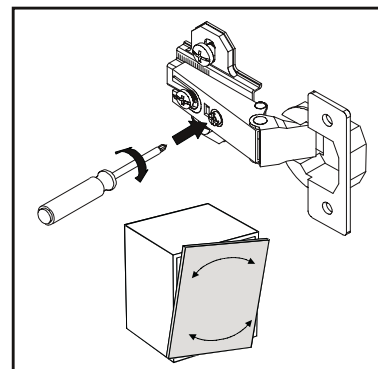
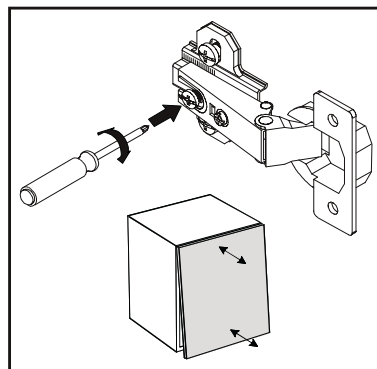
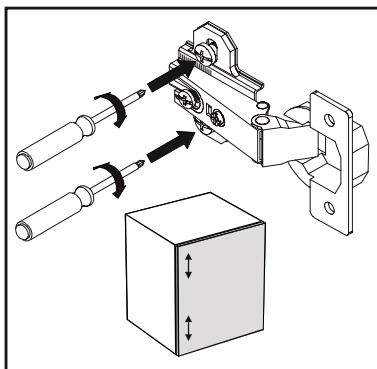
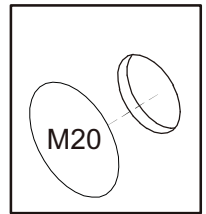
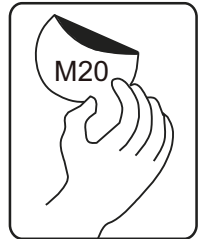
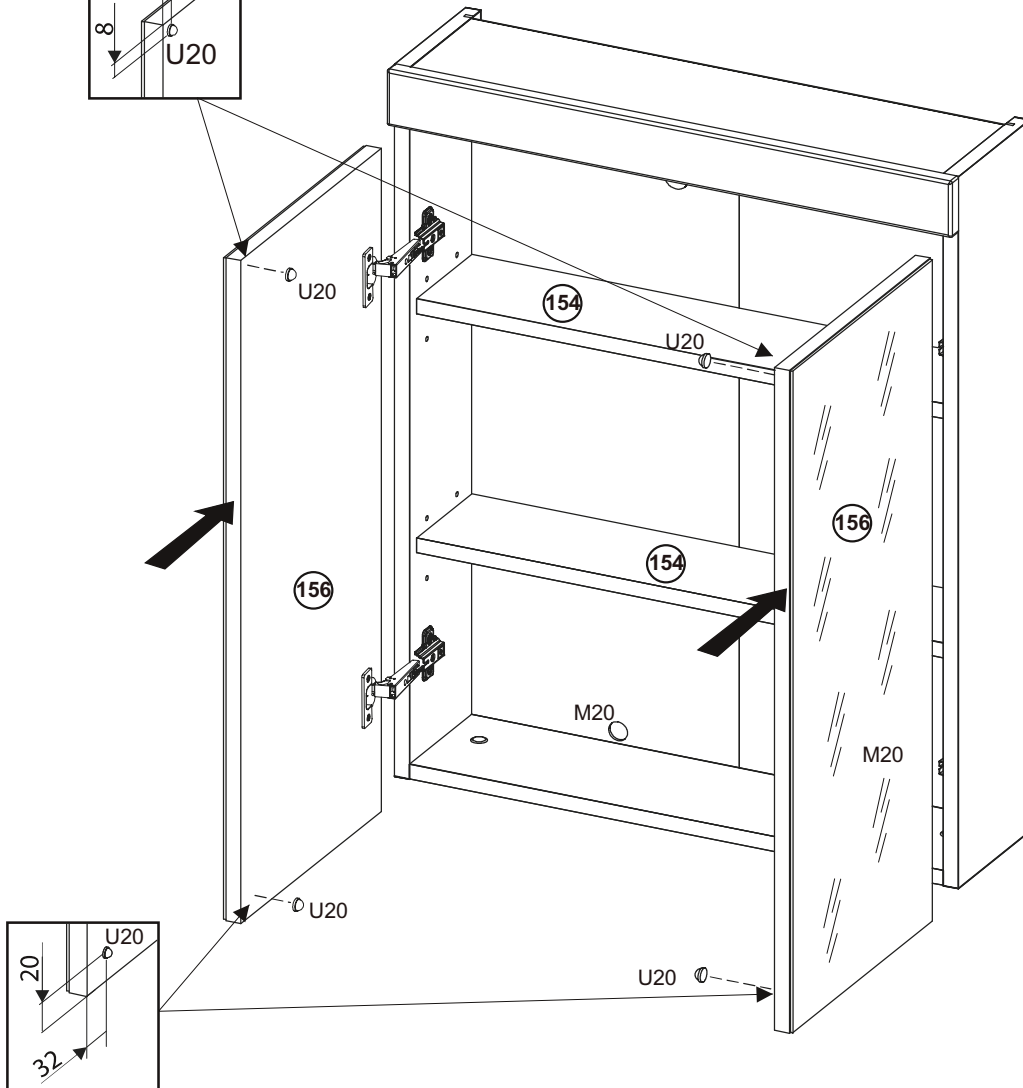
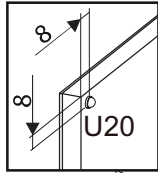
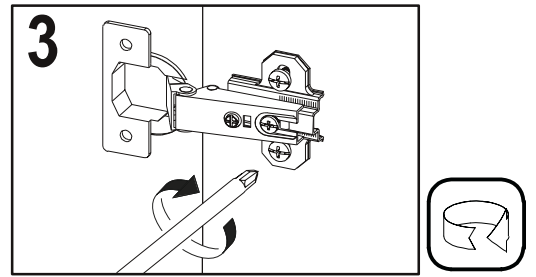
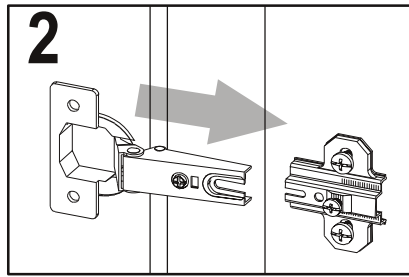
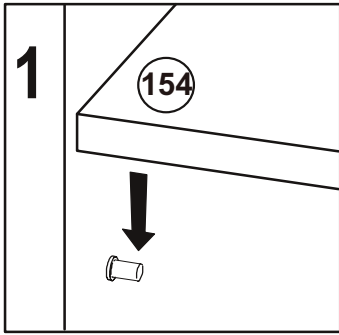

ModelName / Model name / Nom du modèle / Modellnamn
Nome modello / Název modelu / Modelnaam / Ime modela
Numéro Modello / Modell neve / Название модели /
Názov modelu / Ime modela / Denumire model /
Наименование модели / Nazwa modelu

Amanda

Modelnummer / Number / Numéro du modèle
Numero / Номер на модели / modello
Číslo modelu / Modell száma / Číslo modelu
Številka modela / Număr model / Broj modela
Modelnummer / Numer modelu

1393-405-01
1393-405-07

Type / Tipo / Típus / Тип / Тип / Tip

405

D

Unser Direktservice für Beschlagteile
Sollte Ihnen ein Beschlagteil fehlen, können Sie diese Servicekarte direkt an die untenstehende Adresse mailen. Wir können allerdings nur Beschlagteile auf diesem Wege verschicken. Sollten Sie eine andere Beanstandung an Ihrem Möbelstück haben, so wenden Sie sich bitte direkt an Ihr Möbelhaus.

GB

Our direct order service for fitting
If a fitting part is missing, you can e-mail this service card directly to the address below. However, we can only send fitting parts in this way. If you have any other cause for complaint concerning your item of furniture, please contact your furniture store directly.

CZ

Naše přímé služby pro kování
Chybí-li vám nějaký díl z kování, můžete tuto servisní kartu odeslat e-mailem přímo na níže uvedenou adresu. Touto cestou však můžeme zoslat jen díly kování. Pokud byste reklamovali jiný díl nábytku, obraťte se přímo na svého prodejce nábytku.

F

Bien étudier la notice de montage
S'il vous manque une ferrure, veuillez envoyer directement la présente carte service à l'adresse e-mail indiquée ci-dessous. Cependant, ceci nous permet uniquement d'envoyer des ferrures. Pour tout autre type de réclamation concernant votre meuble, veuillez contacter directement votre magasin d'aménagement.

I

Il nostro servizio diretto per l'ordine della ferramenta
Qualora V i dovessate mancare un pezzo di fissaggio, allora V i preghiamo di inviare questa carta di servizio immediatamente all'indirizzo sottostante. Possiamo inviare i pezzi di fissaggio solamente per mezzo di questo procedimento. Qualora dovessate avere qualche altra reclamazione in merito al mobile, allora V i preghiamo di rivolgerV i direttamente al V osto Negozio di mobili.

BG

Наша та директна услуга за обков
Ако липсва ат части от комплекта, попълнете настоящата сервисна карта и ни я изпратете на е-mail адреса, посочен по-долу. По този начин можем да доставим само липсващи елементи от обкова. Ако у установите друг дефект по мебелите, въпросете за обковарите към мебелната къща/магазин, от който сте закупили стоката.

NL

Onze directservice voor losse onderdelen
Wanneer er een onderdeel ontbreekt, kunt u deze servicekaart direct aan onderstaand e-mailadres sturen. Wij kunnen langs deze weg echter alleen beslagdelen versturen. Mocht u een ander probleem aan uw meubel hebben, verzoeken wij u contact op te nemen met uw meubeldealer.

PL

Nasz bezpośredni serwis części montażowych
Jeżeli brakuje części koniecznych do montażu, prosimy o przesłanie nam niniejszej karty serwisowej na niżej podany adres e-mailowy. W ten sposób możemy przesłać Państwu tylko brakujące części. W przypadku innych reklamacji dotyczących mebla, prosimy zgłosić się do salonu meblowego, w którym został dokonany zakup.

HR

Servis za okove
U slučaju da nedostaje neki od dijelova molimo vas da na dolje navedenu mail adresu pošaljete ovaj servisni obrazac. Na ovaj način mogu se dostaviti samo okovi. U slučaju da imate dodatne prigovore vezane uz komad namještaja molimo vas da se obratite izravno trgovini namještaja gdje je isti kupljen.

HU

Direktszolgáltatunk vasalátok esetén
Ha hiányzik egy vasalat, ezt a kártyát közvetlenül elküldheti az alább található címre. Azonban csakis vasalátokat tudunk így küldeni. Amennyiben másfajta reklamációt áll fenn bútorárbáját illetően, forduljon közvetlenül a bútorházhöz.

SK

Náš priamy servis pre časti kovania
Ak by Vám chýbala nejaká časť kovania, môžete poslať túto servisnú kartu poslať e-mailom na nižšie uvedenú adresu. Díly kovania vieme poslať iba týmto spôsobom. Ak by ste mali inú reklamáciu ohľadom Vášho nábytku, obráťte sa priamo na Vašu predajňu nábytku.

SLO

Naše direktno uslužne storitve za okovje
Če vam manjka kakšno okovje, lahko to servisno kartico pošljete po e-pošti direktno na spodnji naslov. Po tej poti vam lahko pošljemo samo okovje. Če želite reklamirati kakšen drug del pohištva, se obrnite neposredno na vašo trgovino pohištva.

RO

Service-ul nostru direct pentru feronerie
În cazul în care vă lipsește o piesă de feronerie puteți să trimiteți direct acest card de service prin e-mail la adresa de mai jos. Noi nu putem expedia piese de feronerie decât pe această cale. Dacă aveți o altă reclamație referitoare la piesa de mobilier atunci vă rugăm să vă adresați direct la magazinul dvs. de mobilă.

RUS

Наш прямой сервис для поставки фурнитуры
Если окажется, что у Вас не хватает того или иного элемента фурнитуры, Вы можете отправить сервисную карту по факсу непосредственно на нижеприведенный электронный почтовый адрес. Однако, таким образом мы можем переслать только фурнитуру. Если же у Вас возникнут иные претензии относительно приобретенной мебели, пожалуйста, обращайтесь непосредственно в организацию, осуществляющую продажу.

S

Vår direktservice för beslagsdelar
Om du saknar en beslagsdel kan du skicka detta servicekort direkt till e-postadressen som anges nedan. Tank på att detta är den enda möjligheten att skicka beslagsdelar till dig. Om du vill reklamera din möbel av en annan anledning måste du kontakta ditt möbelhus direkt.

ES

Nuestro servicio directo para accesorios
Si le falta algún accesorio, puede enviar esta tarjeta de servicio directamente a la siguiente dirección. No obstante, por este método solo podemos enviar accesorios. Si tiene alguna otra objeción sobre su mueble, consulte directamente con su mueblería.

TR

Donatılar için doğrudan servisimiz
Bir donatınız eksikse bu servis kartını doğrudan aşağıda bulunan adrese doğrudan mail yazabilirsiniz. Sadece bu yolla donatılar gönderilebilir. Mobilyanızda başka şikayetleriniz varsa lütfen doğrudan mobilya satıcınıza danışın.

OPTION

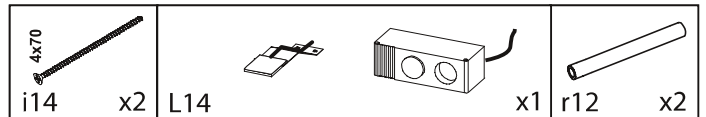
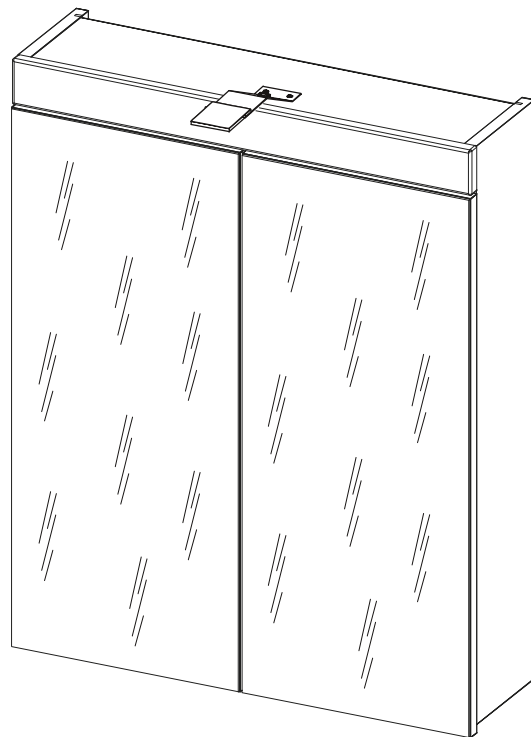

LKZ: 80461

Grund der Beanstandung / Reason of the objection:

Möbelhaus / Furniture store:

Name / Name:

Telefon / Telephone:

PLZ / postal code:

Ort / City:

Strasse / Street:

Haus-Nr. / House No.:

@E-Mail:

E-Mail Kundenservice / Customer service e-mail / E-mail servisního střediska / E-mail de notre service client

è / e-mail servizio clienti / E-mail на отдела за

обслуживание на клиента / E-mail klantenservice / E-mail servisu dla klientów / Servisna mail adresa / Az ügyfélszolgálat e-mail címe / E-mail zákaznického servisu / E-pošta Servisna služba / E-mail Serviciu clientj / E-Mail

сервисной службы / E-postadress kundservice / Servicio de atención por correo electrónico / Müşteri hizmetleri e-postası

service-tt@trendteam.eu

Hotline: +49 5233 955 0367

Fax: +49 5233 955 0467

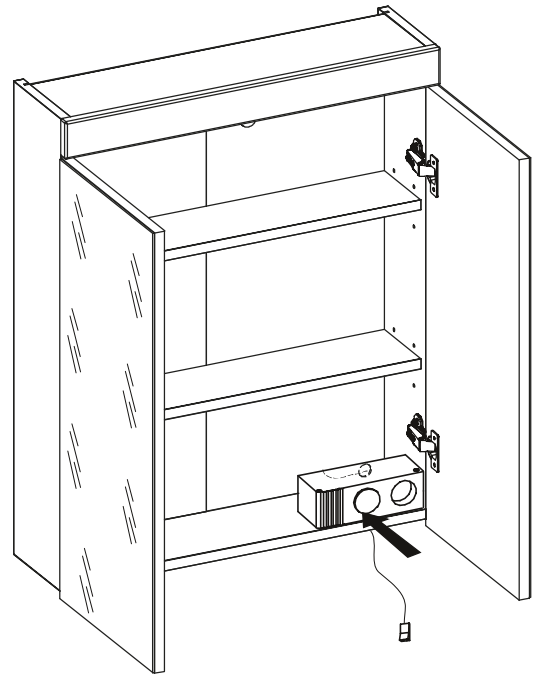
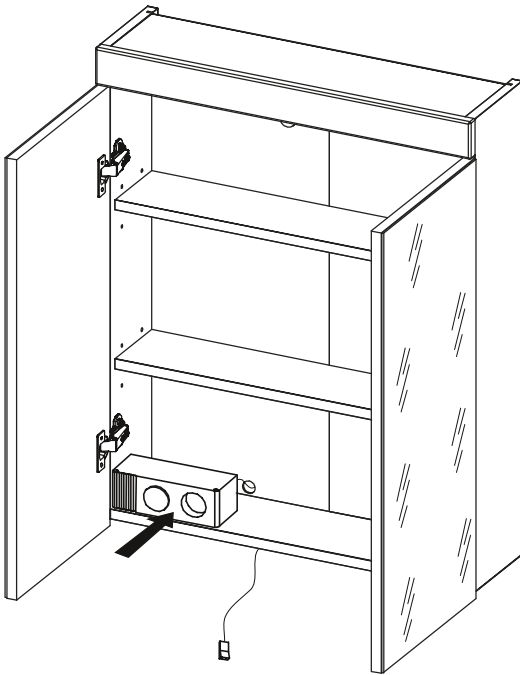
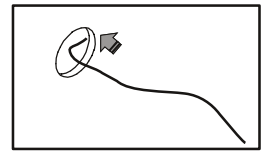
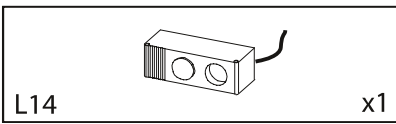
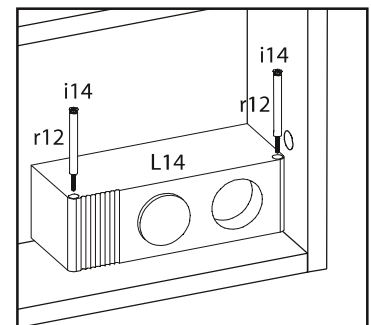
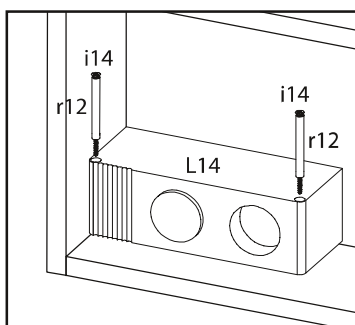
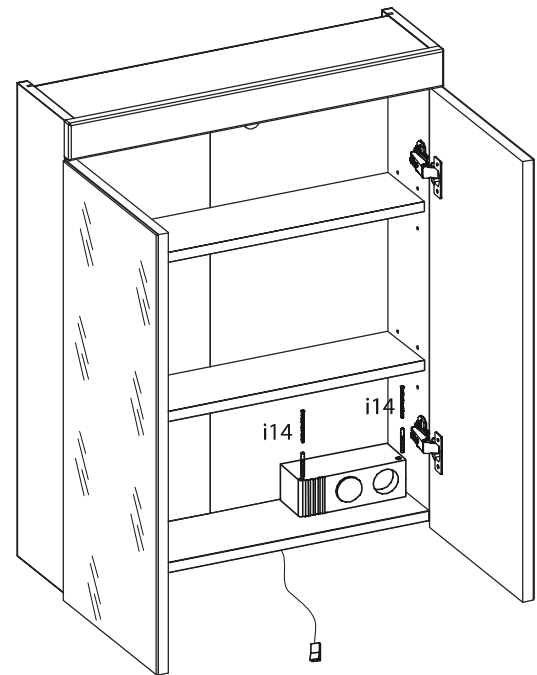
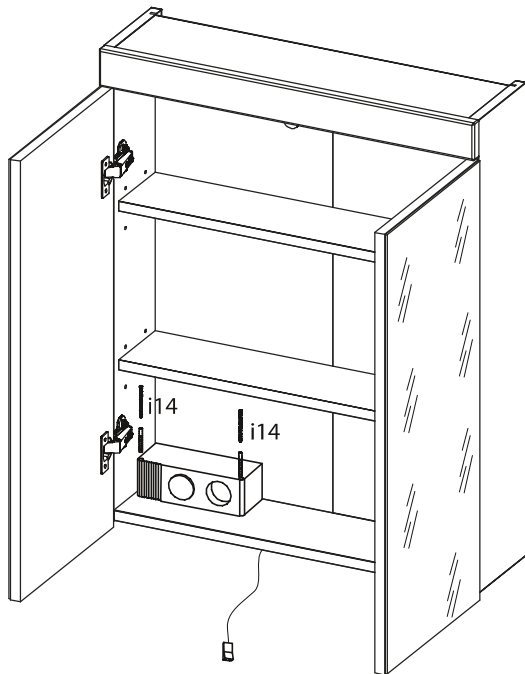
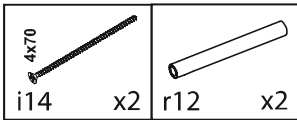
A**B**

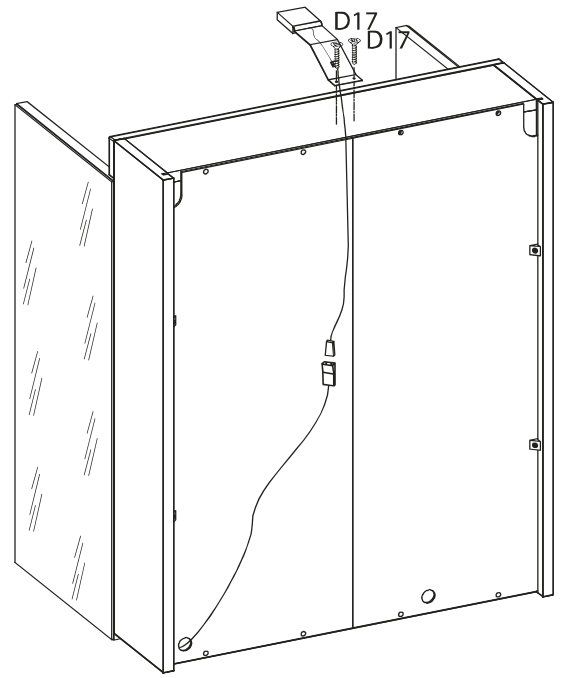
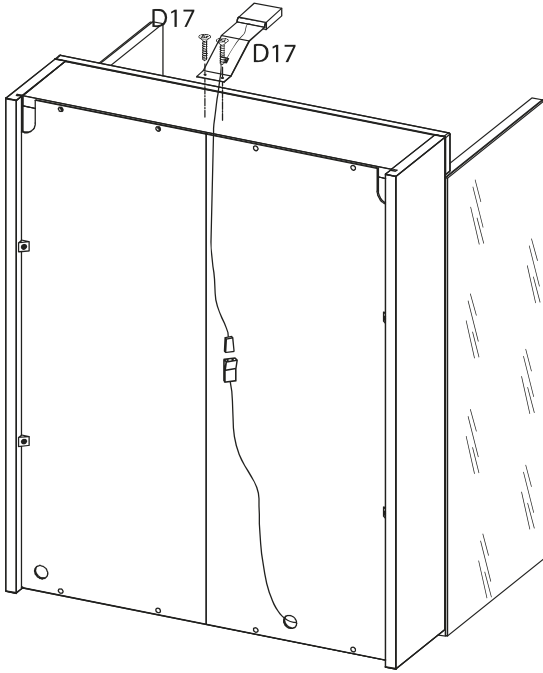
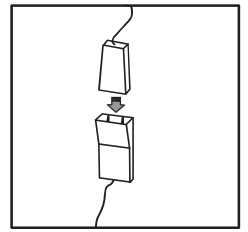
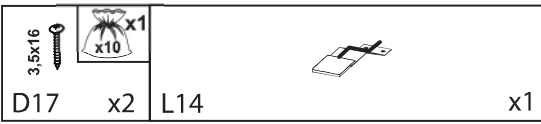
C**D**